



K19-2030-0 Can-am Defender front bumper

REMOVE CONTENTS FROM BOX. VERIFY ALL PARTS ARE PRESENT. READ INSTRUCTIONS CAREFULLY BEFORE STARTING INSTALLATION. ASSISTANCE IS RECOMMENDED TO AVOID POSSIBLE INJURY OR DAMAGE TO THE VEHICLE.

- Start at the front of the vehicle. Carefully pull the bottom of the center grille outward to release from clips and remove the center grille
 - Models with factory brush guard, remove brush guard.



- Select the Mounting Bracket. Insert 2 Bracket Spacers into the pockets into top of the grille opening (FIG. 2 & 3). Hold the Bracket in place over the Spacers (FIG.4). Attach the Bracket to the Spacers and inner crossmember with the included (2) 8mm x 100mm Hex Bolts, (4) 8mm Flat Washers, (2) 8mm Lock Washers and (2) 8mm Hex Nuts(FIG.3 & 5). Do not fully tighten hardware.

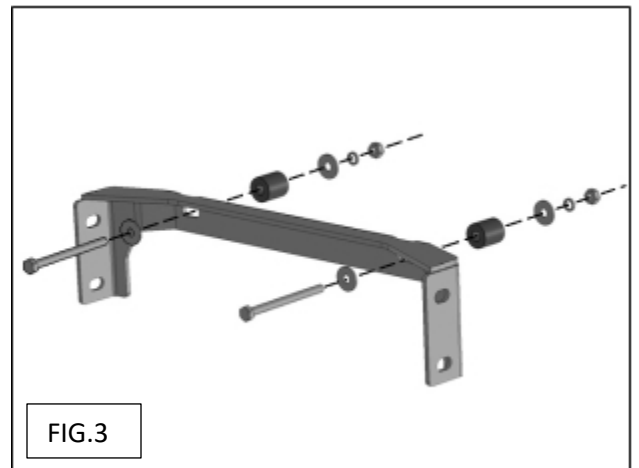
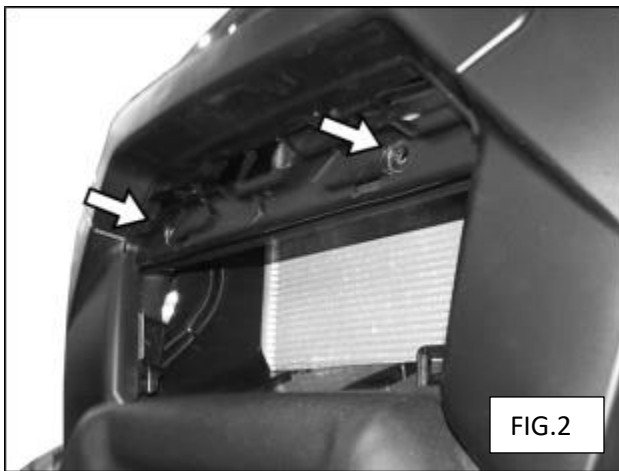

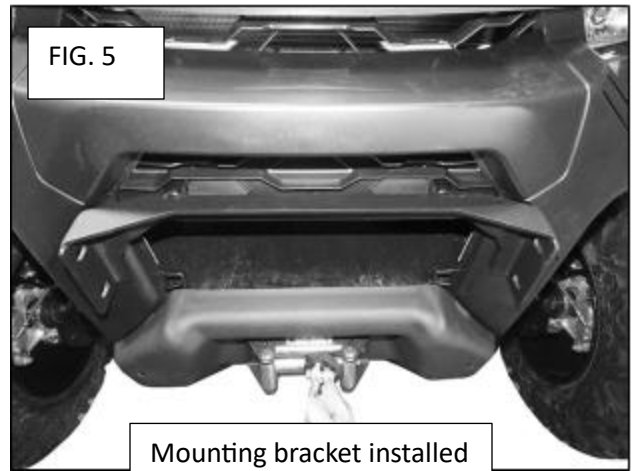
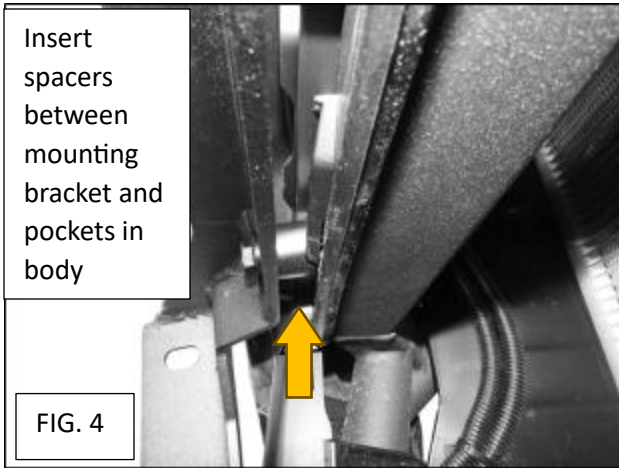

- With assistance, hold the bumper up to the outside of the Mounting Bracket. Attach the tabs on the back of the Bumper to the Mounting Bracket with the included (4) 10mm x 30mm Hex Bolts, (8) 10mm Flat Washers, (4) 10mm Lock Washers and (4) 10mm Hex Nuts. Do not fully tighten hardware at this time (FIG. 6 & 7).

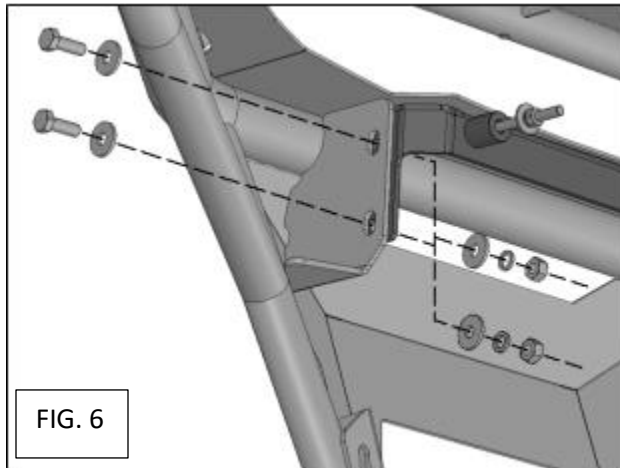

- Attach the Bumper to holes in factory skid plate with the included (2) 8mm x 25mm Hex Bolts, (4) 8mm Flat Washers, (2) 8mm Lock Washers and (2) 8mm Hex Nuts (FIG. 8 & 9). Level and adjust the bumper and tighten all hardware. Optional accessory light bracket holes are pre-drilled.

