



K19-2020-0 Ranger front bumper installation

REMOVE CONTENTS FROM BOX. VERIFY ALL PARTS ARE PRESENT. READ INSTRUCTIONS CAREFULLY BEFORE STARTING INSTALLATION. ASSISTANCE IS RECOMMENDED.

Step 1-

- Start installation at the front of the vehicle. Remove the factory front bumper.
- Select the Winch Mount Bracket. Attach the top of the Bracket to the threaded holes in the frame with the included (2) 10mm x 25mm Hex Bolts, (2) 10mm Lock Washers and (2) 10mm Flat Washers, **(Figure 1)**. Leave hardware loose at this time. Attach the bottom of the Winch Bracket to the front of the frame with the included (2) 10mm x 35mm Carriage Bolts, (2) 10mm Flat Washers, (2) 10mm Lock Washers and (2) 10mm Hex Nuts, **(Figure 1)**. Fully tighten hardware at this time. Follow instructions supplied by winch manufacturer to attach the winch to the Winch Mount, (installation optional-winch not included).

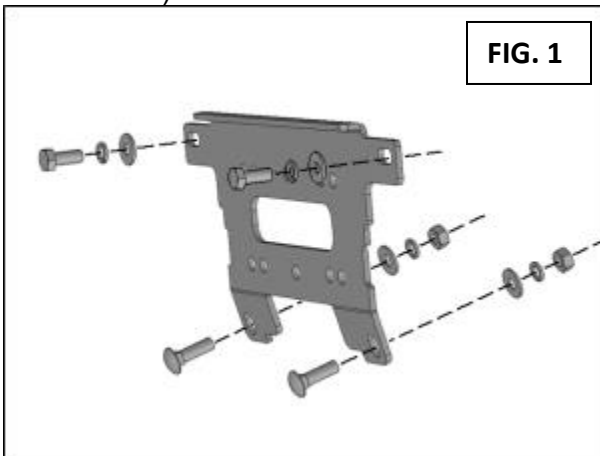

- With assistance, hold the Bumper assembly up to the outside of the upper mounts on the frame. Support Bumper on stands or blocks. Line up the driver/left mounting plate on the back of the Bumper with the outer hole in the tab on the frame mount. Attach the Bumper to the tab with the included (1) 10mm x 35mm Hex Bolt, (2) 10mm Flat Washers, (1) 10mm Lock Washer and (1) 10mm Hex Nut, **(Figures 2 & 3)**. Repeat this step to attach the passenger/right side of the Bumper to the frame mount. Do not fully tighten hardware at this time.

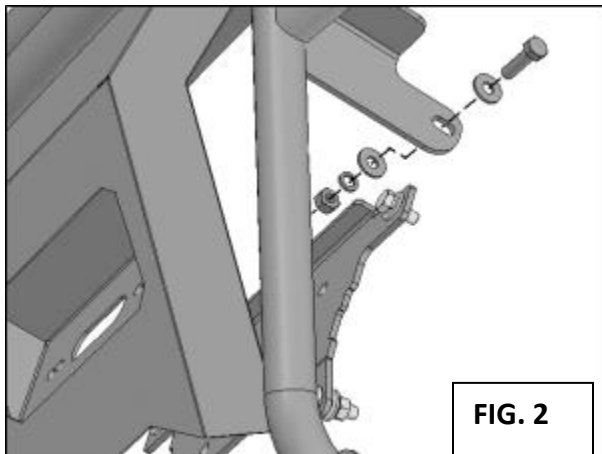

- Attach the bottom mount on the Bumper to the bottom of the frame with the included (2) 8mm x 25mm Hex Bolts, (4) 8mm Flat Washers, (2) 8mm Lock Washers and (2) 8mm Hex Nuts.

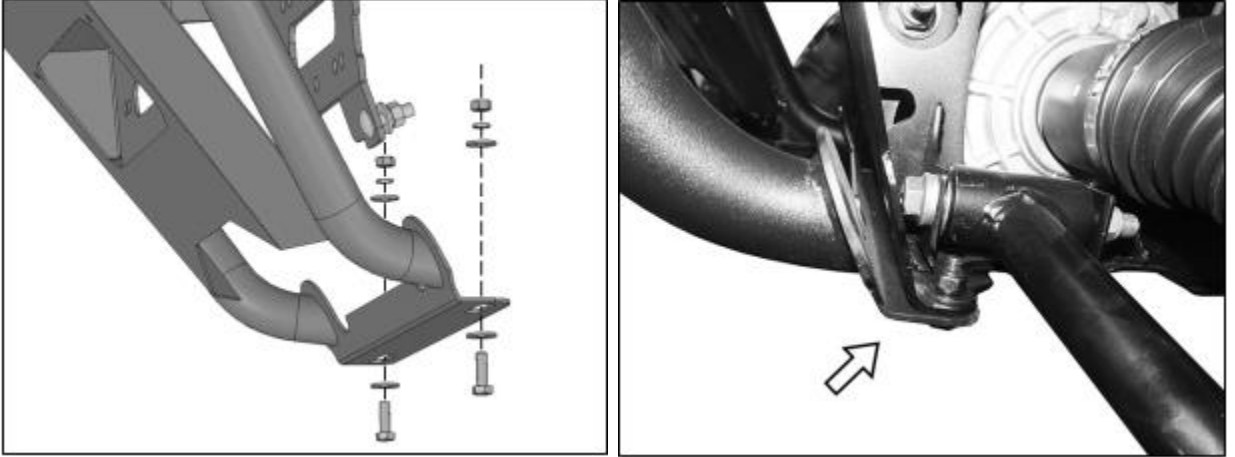

- Level and adjust the Front Bumper and fully tighten all hardware.

Optional accessory light bracket holes are pre drilled into bumper.



Zbrozracing.com

customerservice@zbrozracing.com

435-753-7774